

GETEK[®]

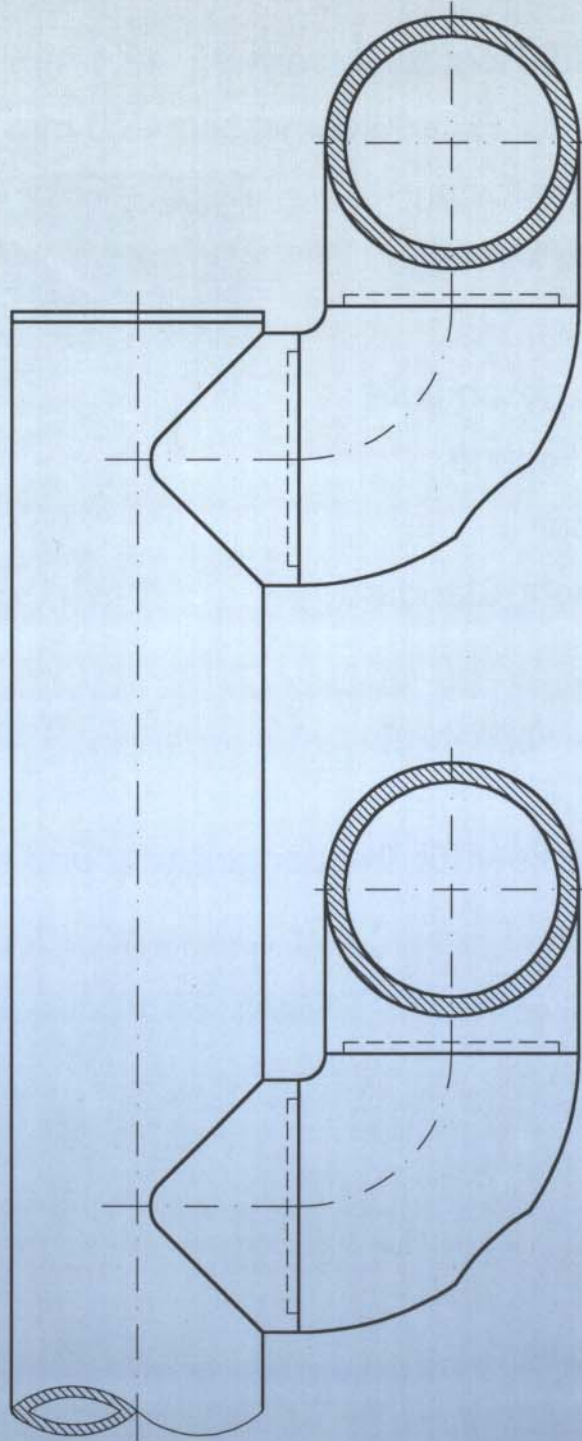

***Multifunktionales
Systemgeländer***

Geländersystem „Universal“

Reg.Nr.: DBGM 69304145

Ausführung Edelstahl für Rohrdurchmesser: 42,4 mm

Ausführung Aluminium für Rohrdurchmesser: 48,3 mm

- Vorgefertigte Geländerpfosten
- Schnelle und einfache Montage
- Kein Schweißen
- Alle Verbindungsteile geschraubt
- Schrauben verdeckt liegend
- Jederzeit demontierbar
- Geländerholme bis Rohr-Standardlänge montierbar
- Hohe Stabilität
- Minimaler Verschnitt
- Stufenlos winkelverstellbar für Treppengeländer und Handläufe



Bodenflansch Nr.: 45 Alu 1½“
(Floor Flange)

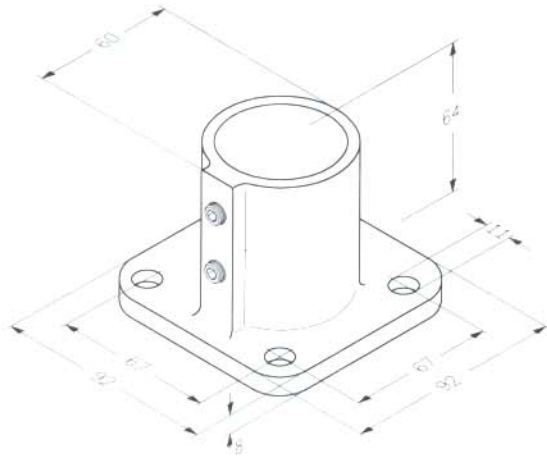

Bodenflansch Nr.: 45 Est 1¼“
(Floor Flange)

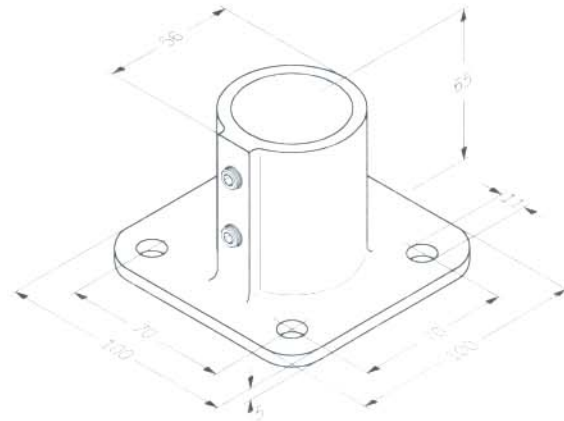

Bodenflansch mit Sockel
Nr.: 49 Alu 1½“
(Floor Flange with Bracket)

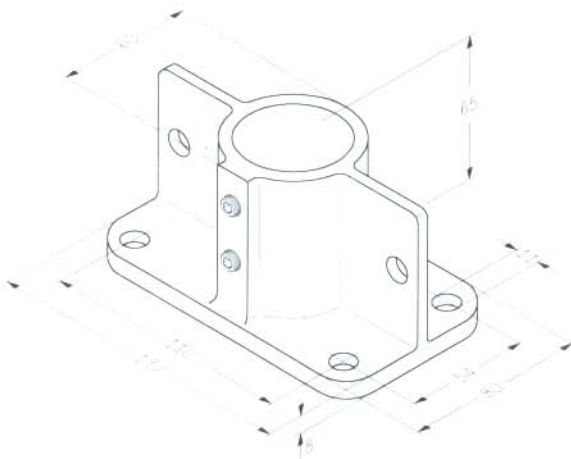

Bodenflansch mit Sockel
Nr.: 49 Est 1¼“
(Floor Flange with Bracket)

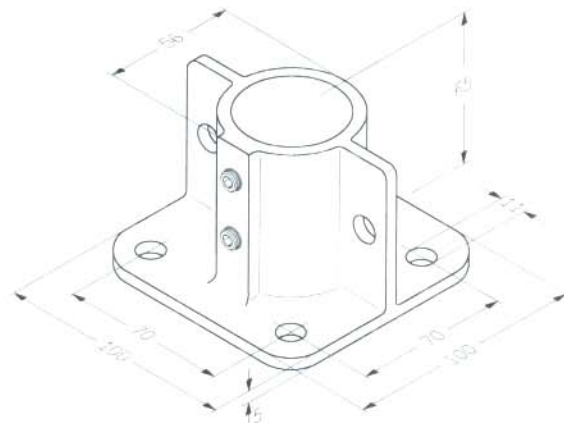

Wandflansch Nr.: 50 Alu 1 1/2"
(Wall Flange)

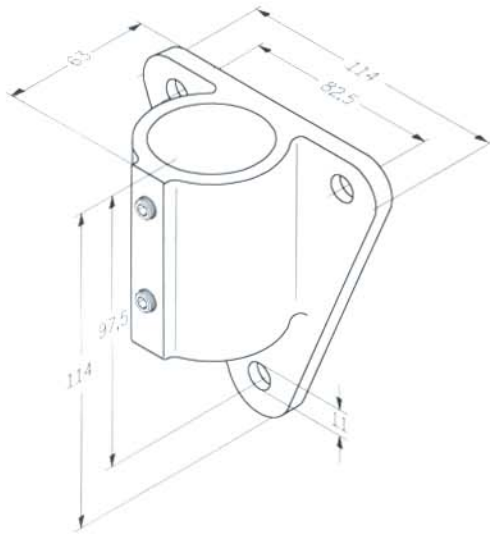

Wandflansch Nr.: 50 Est 1 1/4"
(Wall Flange)

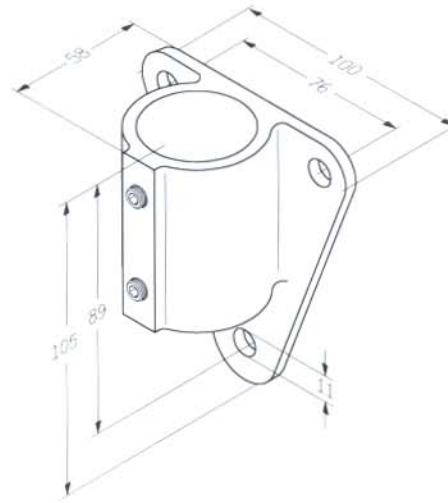

90° Rohrbogen Nr.: 130 Alu 1 1/2"
(Pipe Ellbow)

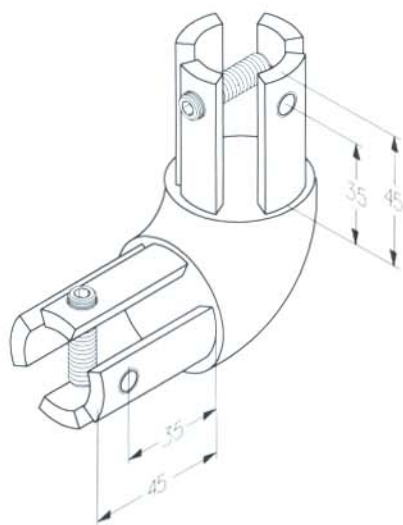

90° Rohrbogen Nr.: 130 Est 1 1/4"
(Pipe Ellbow)

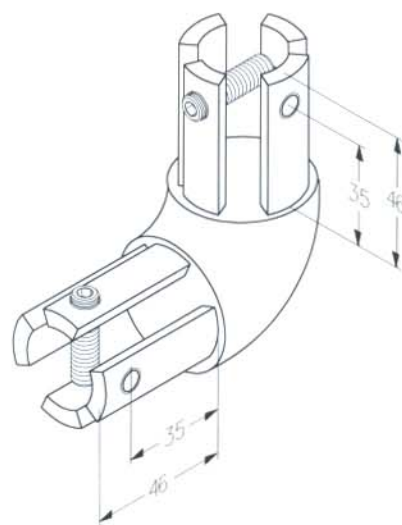

Endkappe für Rohr
Nr.: 62P Alu 1½“
(Plug)

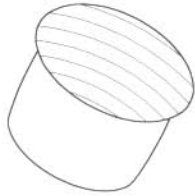

Endkappe für Rohr
Nr.: 62P Est 1¼“
(Plug)



Innenkupplung Nr.: 70 Alu 1½“
(Insert Coupling)

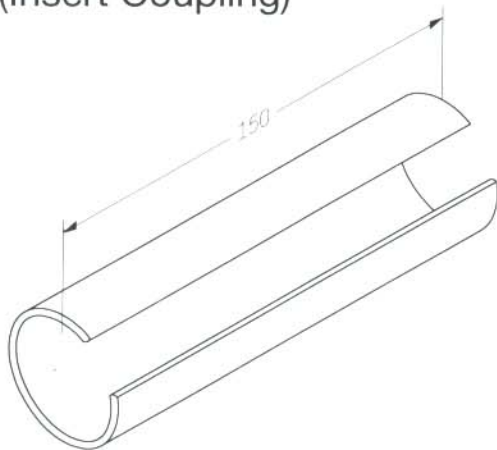

Innenkupplung Nr.: 70 Est 1¼“
(Insert Coupling)

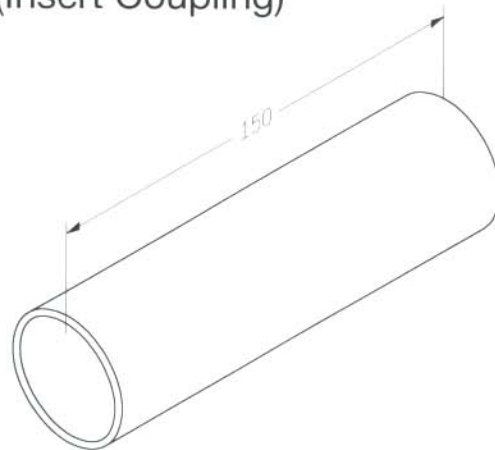

Rohrbogen mit
Innenkupplungen
Nr.: 132 Alu 1½“
∠ β nach Angabe

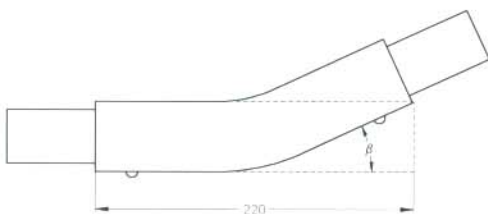

Rohrbogen mit
Innenkupplungen
Nr.: 132 Est 1¼“
∠ β nach Angabe

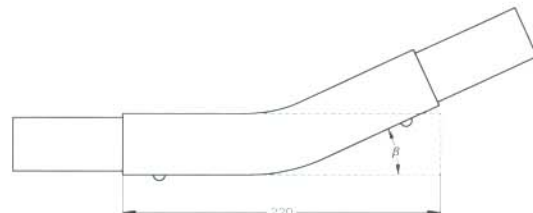

Bei Bestellung angeben: Blindnietkopf an Außen-oder Innenbogen (dargestellt an Außenbogen).

Rohrverbinder Nr.: 136 Alu 1½“
Nr.: 136 Est 1¼“

(Pipe Connector)

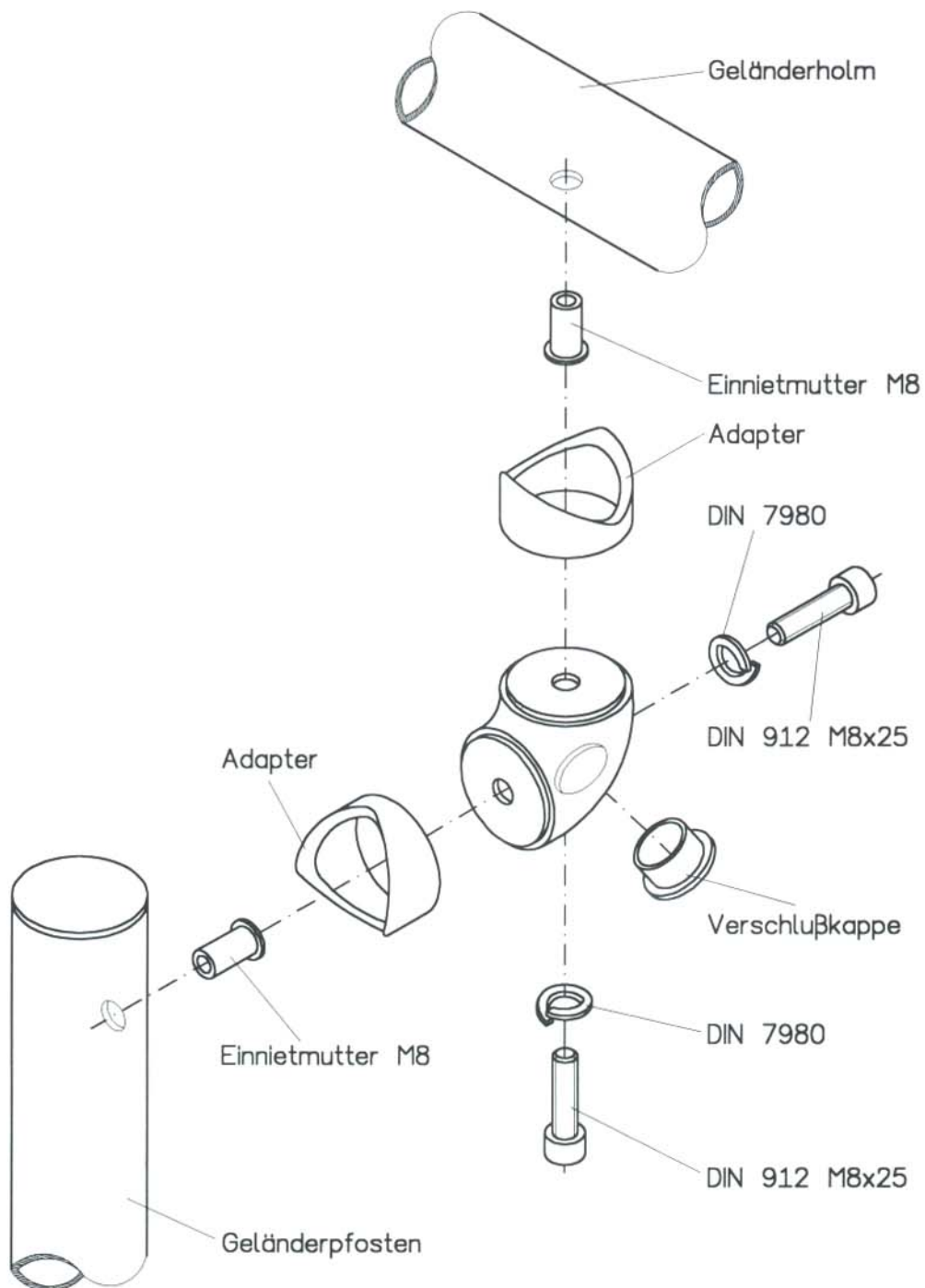

Wandkonsole Nr.: 138 Alu 1½“

Nr.: 138 Est 1¼“

(Wall Bracket)

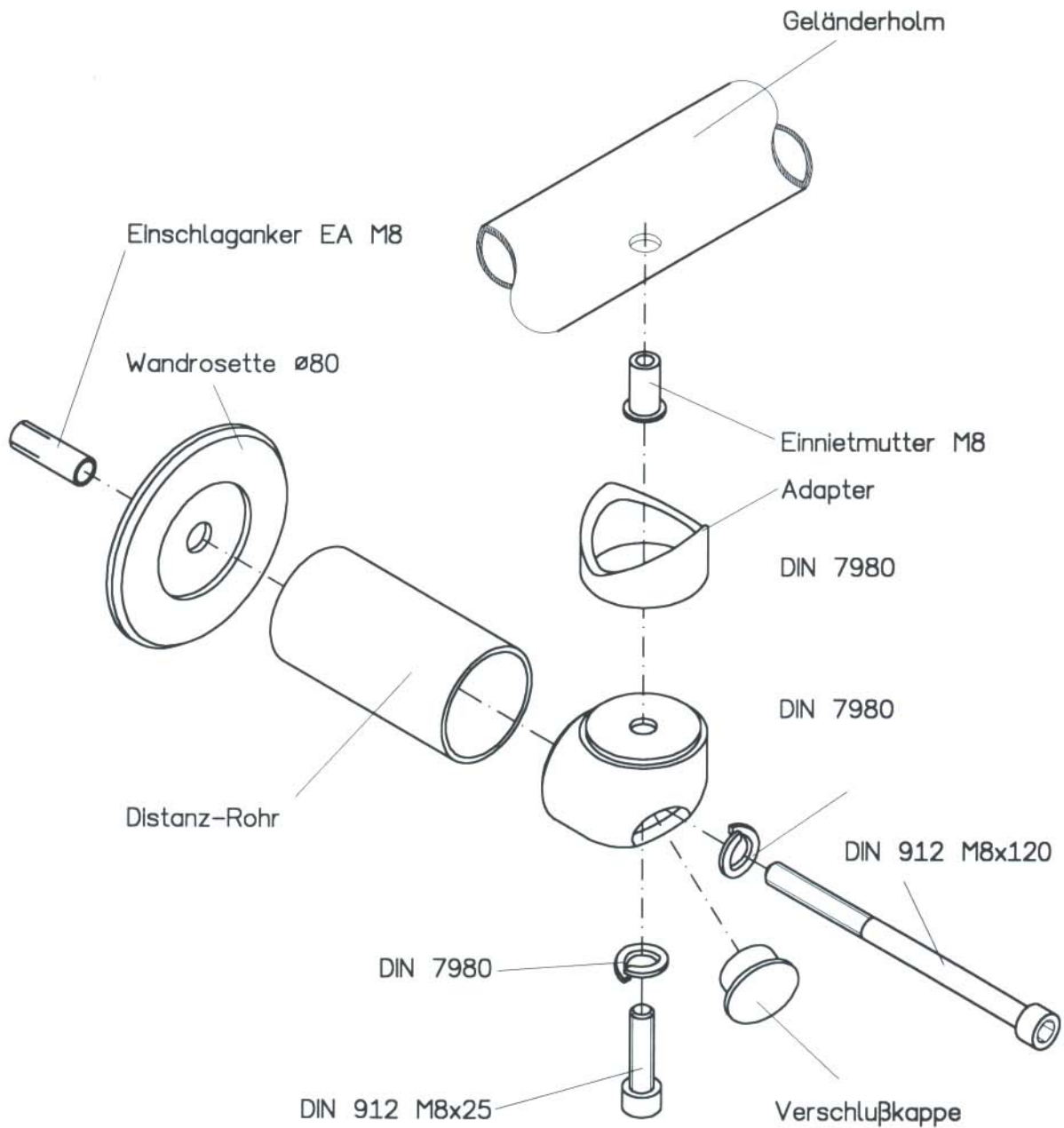

Geländertüren

Ausführung Alu - Aluminiumrohr 1 1/2"

Ausführung Est - Edelstahlrohr 1 1/4"

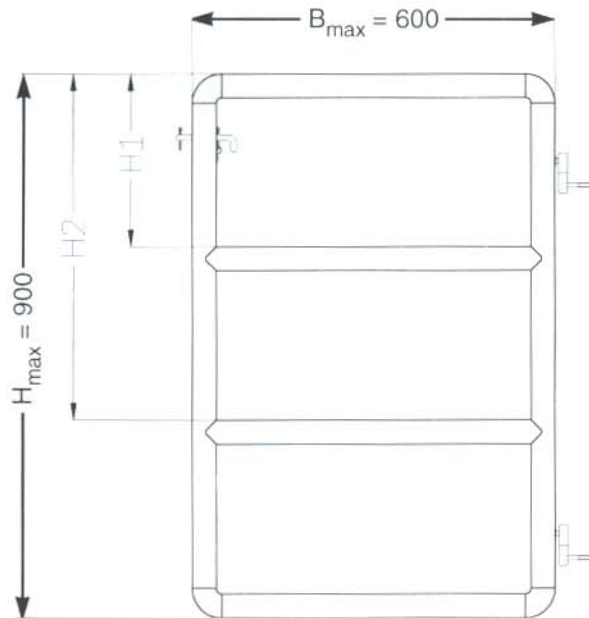

Typ I





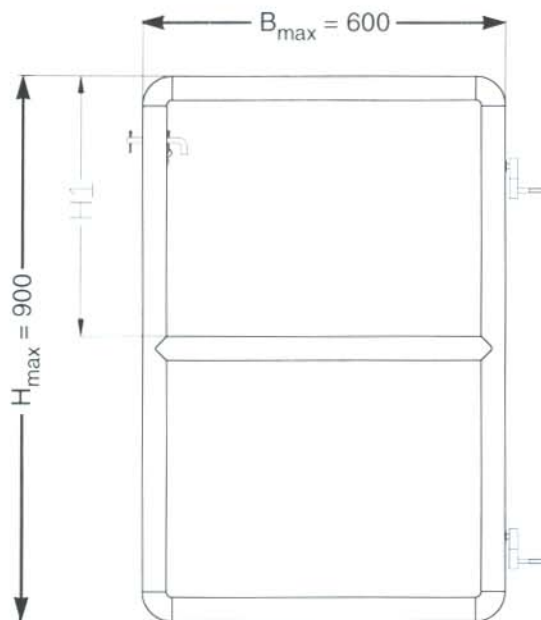



Bei Bestellung angeben:

1. Ausführung
2. Typ
3. Maße: B, H, H1, H2



Typ II

Pfostentypen

 <p>Typ A</p>	 <p>Typ B</p>	 <p>Typ C</p>	 <p>Typ D</p>
 <p>Typ E</p>	 <p>Typ F</p>	 <p>Typ G</p>	 <p>Typ H</p>

Bestell-Nr. der verschiedenen Pfostentypen

Pfosten- länge*	Typ A		Typ B		Typ C		Typ D		Typ E		Typ F		Typ G		Typ H	
	Est	Alu	Est	Alu	Est	Alu	Est	Alu	Est	Alu	Est	Alu	Est	Alu	Est	Alu
bis 1,00m	601	602	603	604	605	606	607	608	609	610	611	612	613	614	615	616
1,01 – 1,20m	617	618	619	620	621	622	623	624	625	626	627	628	629	630	631	632
1,21 – 1,50m	633	634	635	636	637	638	639	640	641	642	643	644	645	646	647	648

*Pfostenlänge Typ A - D = Geländerhöhe \div 50 mm



*Pfostenlänge Typ E - H = Geländerhöhe \div 50 mm + Überstand



Geländersystem „Speed-Rail“

Ausführung Aluminium für Rohrdurchmesser lt. Tabelle

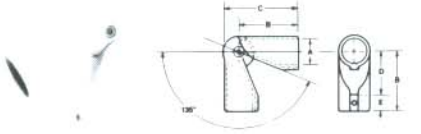
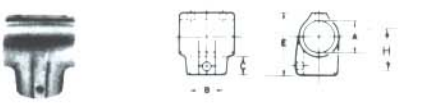
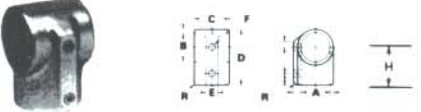
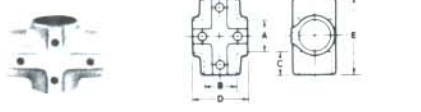
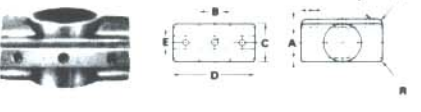
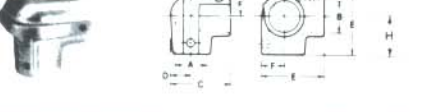
- Schnelle und einfache Montage
- Kein Schweißen
- Alle Verbindungsteile geschraubt
- Jederzeit demontierbar
- Hohe Stabilität
- Geringes Gewicht
- Große Auswahl an Formteilen
- Verwendbar für alle Arten von Rohrkonstruktionen
- Klemmschrauben aus Edelstahl
- Einziges Werkzeug: Innensechskant-Schlüssel

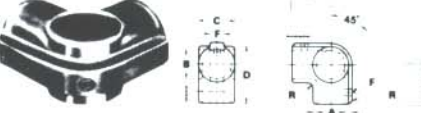

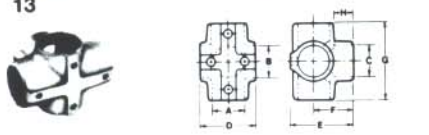
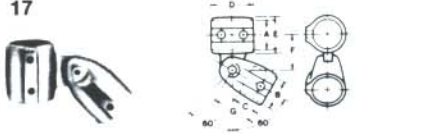
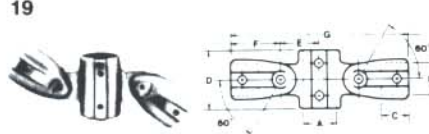
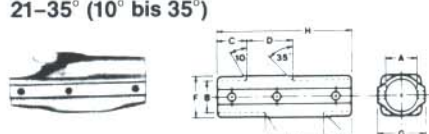
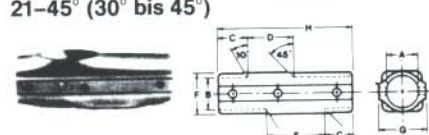
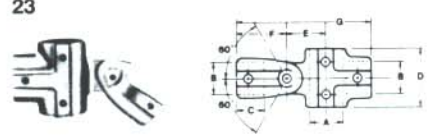
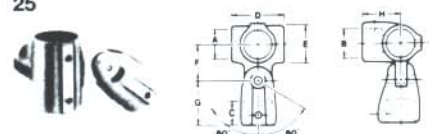
Typ	A	B	C	D	E	F	G	H
3 	1/2"	21,6	34,1	25,4	54,0			
	3/4"	27,1	38,1	25,4	61,1			
	1"	34,0	45,2	28,5	73,0			
	1-1/4"	42,7	50,8	30,1	80,9			
	1-1/2"	49,0	58,8	34,9	95,2			
	2"	61,0	76,2	44,4	117,5			
3 AE 	1-1/4"	42,7	101,6	123,9	60,3	38,1		
5 	1/2"	21,6	21,6	22,2	42,8	54,0		
	3/4"	27,1	27,1	22,2	50,8	59,5		
	1"	34,0	34,0	25,4	60,3	72,2		
	1-1 1/4"	42,7	42,7	25,4	70,0	81,7		
	1-1/2"	49,0	49,0	30,1	85,7	94,4		
	2"	61,0	61,0	66,7	101,6	117,4		
5 E 	3/4"	27,2	27,2	38,1	57,2	12,7	5/16-18	38,1
	1"	34,0	34,0	44,5	66,7	14,3	3/8-16	44,5
	1 1/4"	42,7	42,7	50,8	76,2	15,9	3/8-16	50,8
	1 1/2"	49,0	49,0	58,7	85,7	15,9	3/8-16	58,7
7 	1/2"	21,6	21,6	25,4	42,8	72,2		
	3/4"	27,1	27,1	23,8	50,8	76,2		
	1"	34,0	34,0	28,6	60,3	90,5		
	1-1/4"	42,7	42,7	28,6	70,0	101,6		
	1-1/2"	49,0	49,0	33,3	85,7	117,5		
	2"	61,0	61,0	70,0	98,5	152,4		
7 E 	3/4"	27,2	27,2	38,1	76,2	12,7	5/16-18	
	1"	34,0	34,0	44,5	88,9	14,3	3/8-16	
	1 1/4"	42,7	42,7	50,8	101,6	15,9	3/8-16	
	1 1/2"	49,0	49,0	58,7	112,7	15,9	3/8-16	
9 	1/2"	21,6	21,6	51,6		54,0		
	3/4"	27,2	27,2	56,3	18,3	59,5	21,4	
	1"	34,0	34,0	68,3	23,0	71,5	26,2	
	1-1/4"	42,7	42,7	76,2	27,0	82,6	31,0	
	1-1/2"	49,0	49,0	87,3	30,1	94,5	35,0	
	2"	61,0	61,0	112,3	42,8	111,1	41,3	
11 	1/2"	21,6	21,6	42,8	54,0			
	3/4"	27,2	27,2	50,8	60,3	38,1	24,6	59,5
	1"	34,0	34,0	60,3	72,2	45,2	28,6	72,2
	1-1/4"	42,7	42,7	70,0	81,7	50,8	28,6	82,6
	1-1/2"	49,0	49,0	82,6	96,8	58,7	35,0	96,8
	2"	61,0	61,0	98,4	115,9	76,2	46,0	111,1
11 E 	3/4"	27,2	27,2	38,1	57,2	12,7	5/16-18	38,1
	1"	34,0	34,0	44,5	66,8	14,3	3/8-16	44,5
	1 1/4"	42,7	42,7	50,8	76,2	15,9	3/8-16	50,8
	1 1/2"	49,0	49,0	58,7	85,7	15,9	3/8-16	58,7

Typ	A	B	C	D	E	F	G	H
13 	1/2"	21,6	21,6	21,6	42,8	54,0		72,2
	3/4"	27,2	27,2	27,2	50,8	61,1	38,1	76,2
	1"	34,0	34,0	34,0	60,3	73,8	45,2	90,5
	1-1/4"	42,7	42,7	42,7	70,0	83,3	50,8	101,6
	1-1/2"	48,9	48,9	48,9	85,7	94,5	58,7	117,5
17 	1/2"	21,6	21,6	23,8	42,8		31,7	38,1
	3/4"	27,2	27,2	23,8	50,8	34,9	36,5	49,2
	1"	34,0	34,0	27,0	50,8	44,5	41,3	50,8
	1-1/4"	42,7	42,7	36,5	60,3	54,0	51,6	65,0
	1-1/2"	48,9	48,9	44,5	69,8	58,7	55,5	69,8
19 	3/4"	27,1	27,1	23,8	50,8	33,3	49,2	165,1
	1"	34,0	34,0	27,0	60,3	41,3	50,8	184,1
	1-1/4"	42,7	42,7	36,5	69,9	49,2	65,0	228,6
	1-1/2"	49,0	49,0	44,5	85,7	57,1	69,8	254,0
21-35° (10° bis 35°) 	3/4"	27,1	27,1	22,2	33,3	49,2	35,7	42,8
	1"	34,0	34,0	25,4	42,0	60,3	44,5	53,2
	1-1/4"	42,7	42,7	27,0	52,4	74,6	54,0	61,9
	1-1/2"	49,0	49,0	34,1	60,3	87,3	60,3	71,4
21-45° (30° bis 45°) 	3/4"	27,1	27,1	22,2	38,1	49,2	35,7	42,8
	1"	34,0	34,0	25,4	48,4	58,7	44,5	53,2
	1-1/4"	42,7	42,7	27,0	60,3	76,2	54,0	61,9
	1-1/2"	49,0	49,0	30,1	68,2	90,5	60,3	71,4
23 	3/4"	27,1	27,1	23,8	50,8	33,3	49,2	139,7
	1"	34,0	34,0	27,0	60,3	38,9	50,8	134,9
	1-1/4"	42,7	42,7	36,5	69,9	49,2	65,0	165,1
	1-1/2"	49,0	49,0	44,5	85,7	57,2	69,9	185,7
25 	3/4"	27,1	27,1	23,8	50,8	33,3	33,3	49,2
	1"	34,0	34,0	27,0	60,3	40,5	41,3	50,8
	1-1/4"	42,7	42,7	36,5	69,9	50,0	49,2	65,0
	1-1/2"	49,0	49,0	44,5	85,7	57,1	57,1	69,9
27 	3/4"	27,1	27,1	23,8	50,8	33,3	49,2	82,5
	1"	34,0	34,0	27,0	60,3	41,3	50,8	92,0
	1-1/4"	42,7	42,7	36,5	69,9	49,2	65,1	114,3
	1-1/2"	49,0	49,0	44,5	85,7	57,1	69,9	127,0
30 C 	3/4"	27,1	27,1	47,6	65,0	19,4	17,4	25,4
	1"	34,0	34,0	58,7	84,1	27,0	21,0	30,1
	1-1/4"	42,7	42,7	70,6	98,0	32,5	27,0	36,5
	1-1/2"	48,9	48,9	79,4	109,5	38,1	31,0	41,2
	2"	61,0	61,0	89,0	126,2	44,5	35,0	44,5

Typ		A	B	C	D	E	F	G	H	
41		1/2"	21,6	23,8	38,1	28,6	54,0	76,2		
		3/4"	27,0	24,6	49,2	30,2	41,3	73,0	23,8	12,0
		1"	34,0	28,6	50,8	30,2	41,3	73,0	23,8	12,0
		1 1/4"	42,7	49,2	65,0	33,3	52,4	84,5	30,1	15,2
		1 1/2"	49,0	41,3	69,9	33,3	52,4	84,5	30,1	15,2
45		3/4"	27,0	38,1	66,7	44,5	8,0	6,4		
		1"	34,0	46,0	76,2	52,4	8,0	6,4		
		1-1/4"	42,7	54,0	85,7	60,3	11,0	8,0		
		1 1/2"	49,0	64,3	92,0	66,7	11,0	8,0		
46 ADJ		1-1/2"	49,0	120,7	165,1	73,0	114,3	57,15	31,8	49,2
49		1 1/4"	42,7	54,0	128,6	74,6	47,6	103,2	7,9	37,3
		1 1/2"	49,0	64,3	136,5	79,4	54,0	109,5	7,9	39,6
50		3/4"	27,0	82,5	25,4	82,5	50,8	57,1	57,1	4,8
		1"	34,0	98,4	27,0	93,7	57,1	63,5	66,7	6,4
		1 1/4"	42,7	98,4	31,0	106,4	63,5	76,2	66,7	7,9
		1 1/2"	49,0	114,3	34,9	114,3	76,2	82,6	82,6	7,9
		2"	61,0	123,8	40,5	127,0	85,7	95,3	92,0	7,9
52		1 1/4"	42,7	34,1	139,7	101,6	63,5	101,6	72,2	
		1 1/2"	49,0	31,0	139,7	114,3	63,5	89,0	70,6	
60		1/2"	16,0	27,0						
		3/4"	21,2	33,3						
		1"	26,9	39,6						
		1 1/4"	35,3	49,2						
		1 1/2"	41,1	55,5						
		2"	52,7	67,5						
B = Außen-Ø Formteil										
62		3/4"	21,2	26,6						
		1"	26,9	33,4						
		1 1/4"	35,3	42,2						
		1 1/2"	41,1	48,3						
B = Außen-Ø Rohr										
70		3/4"	27,1	63,5						
		1"	34,0	89,0						
		1 1/4"	42,7	89,0						
		1 1/2"	48,9	89,0						
		2"	61,0	101,6						

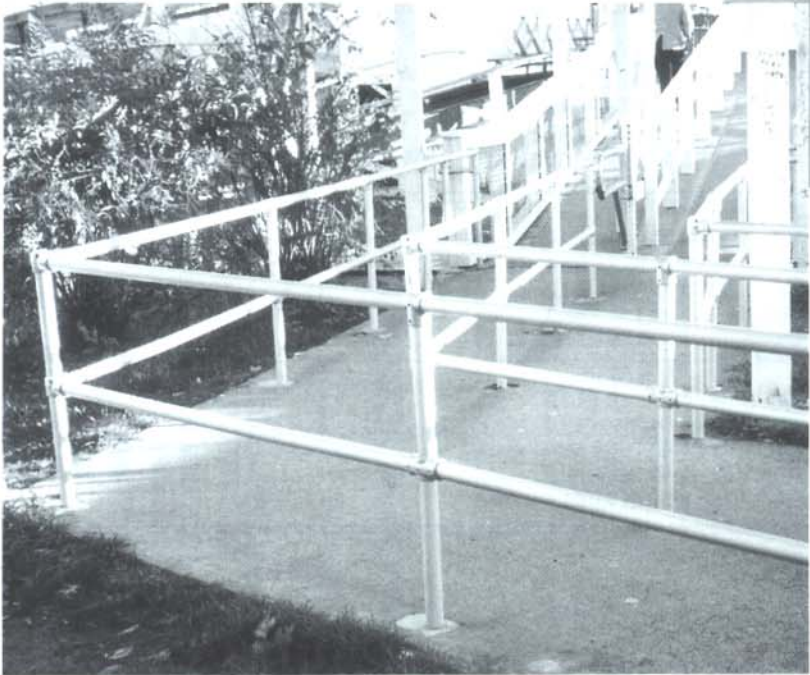
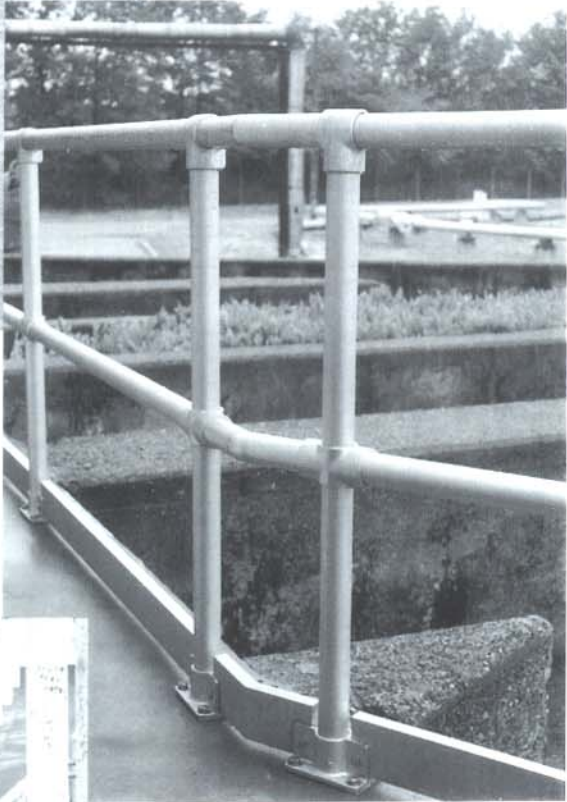

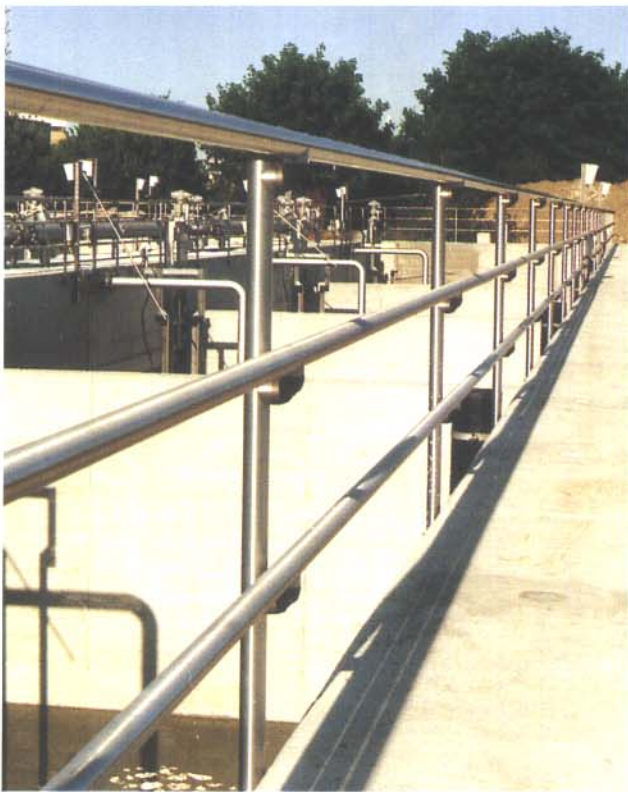



Händlerstempel:

GETEK[®] GmbH
Hajo-Rüter-Straße 14
65239 Hochheim/Main
Telefon: 0 61 46 / 83 51 57
Telefax: 0 61 46 / 83 51 59